

HOW TO MEASURE A TRUCK DRIVESHAFT

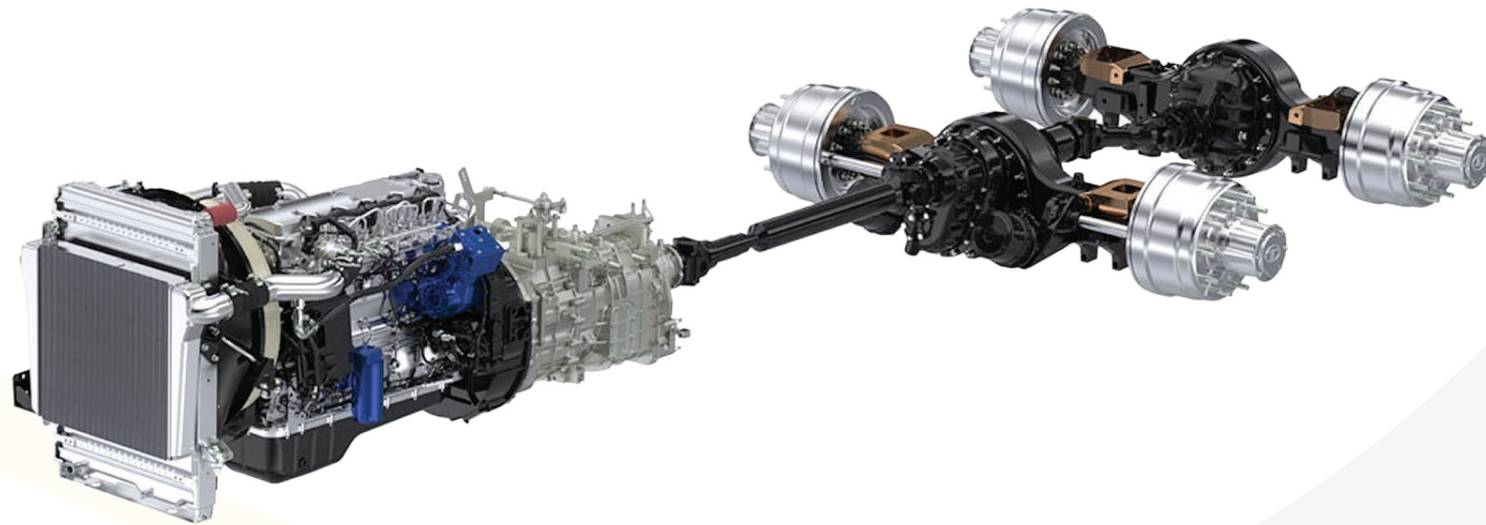

- 1: Identify Universal Joint type
- 2: Measure Universal Joint according to corresponding figure
- 3: Identify driveshaft style ie. single or twin
- 4: Identify driveshaft design Spicer, Spicer Flanged, Wing Type, Euro Std or Euro KV
- 5: Select corresponding measurement guide
- 6: Complete all requested measurements*.

* Measure all shafts with vehicle at “ride height”. If shaft (s) have been removed, measure all shafts in the “fully compressed” position.

IMPORTANT: Measurements must be clearly labeled “working” or “compressed”, as misunderstandings can result in major transmission/diff damage.

Universal Joint Types

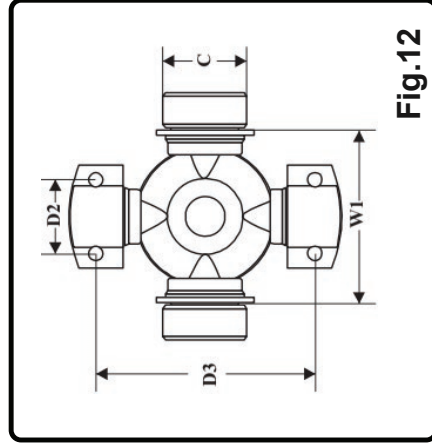
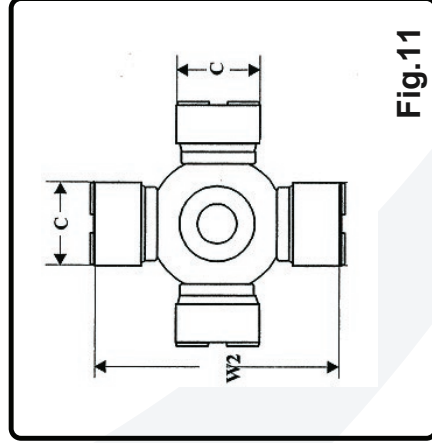
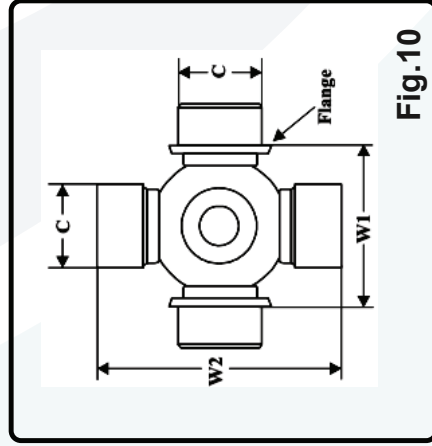
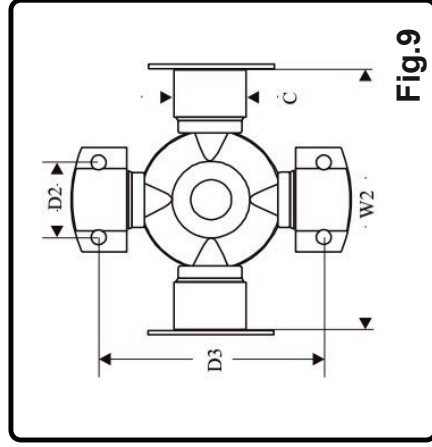
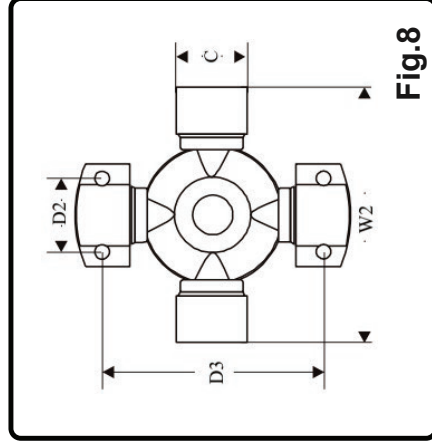
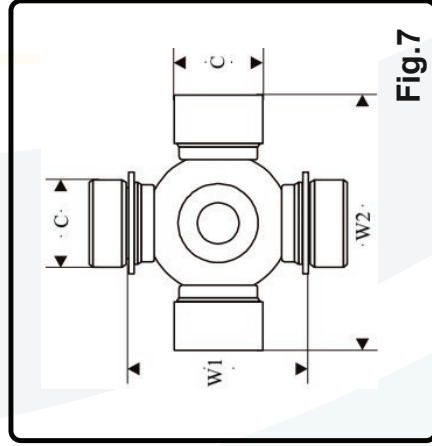
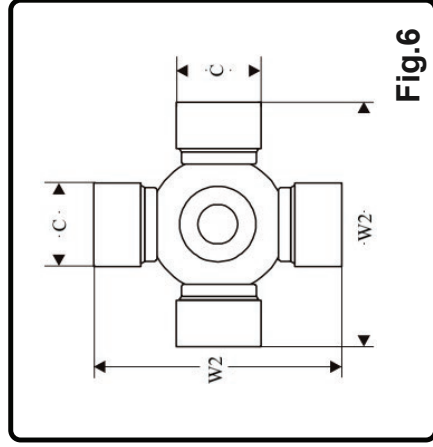
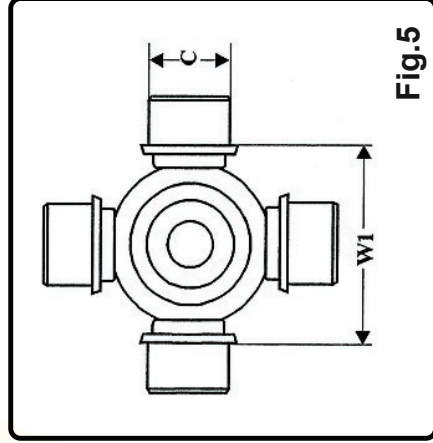
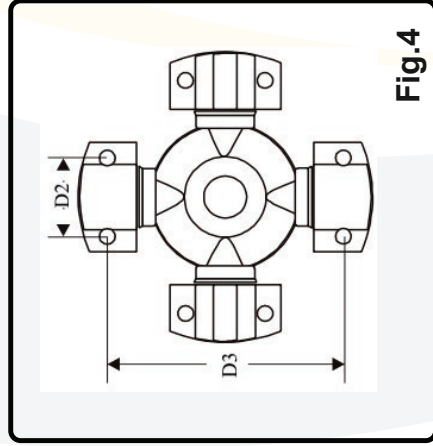
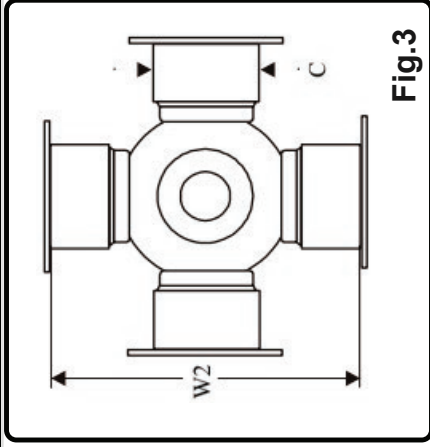
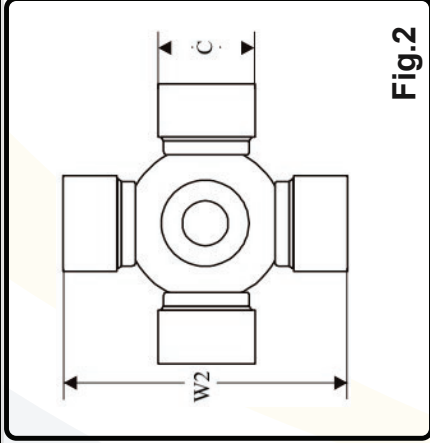
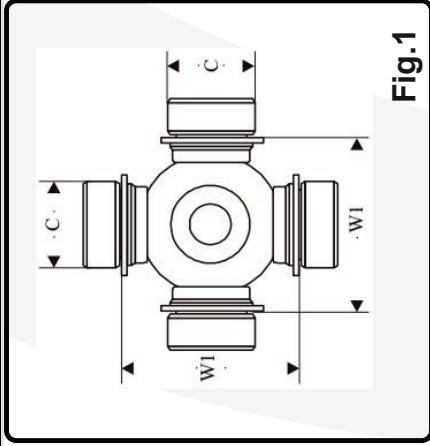

Universal Joint Types

Uni Lubrication Points

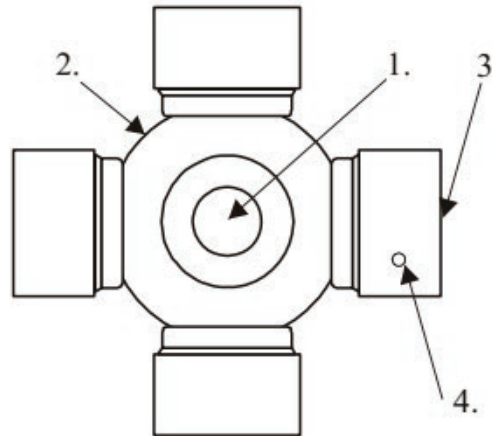

Note: Lubrication points are listed as guide only. This position can alter between joint manufacturers.

T = Tapped | D = Drilled & C/Bore

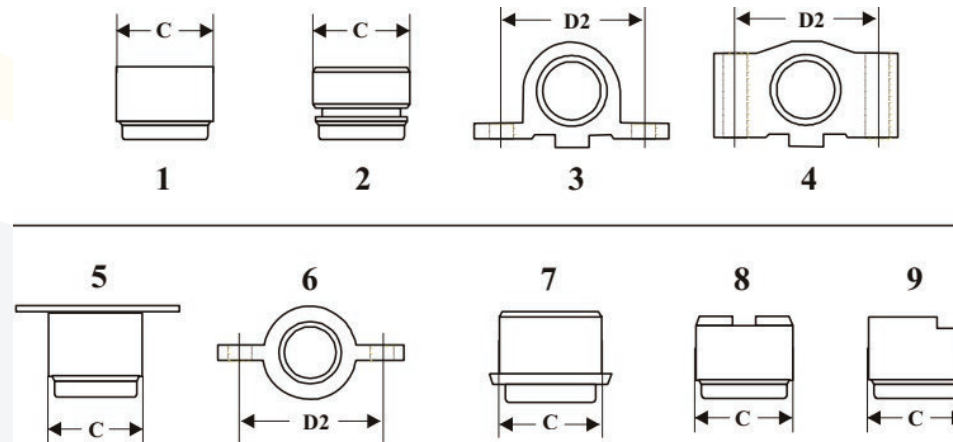

STANDARD SPICER SINGLE-PIECE SHAFT (WITHOUT FLANGES)

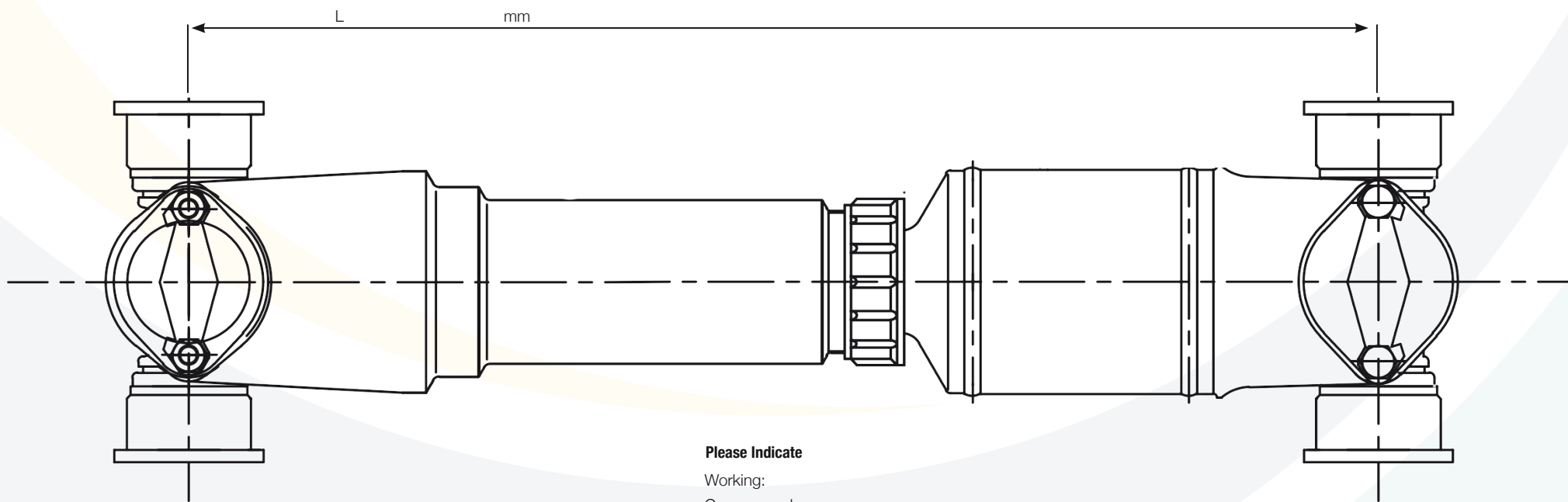

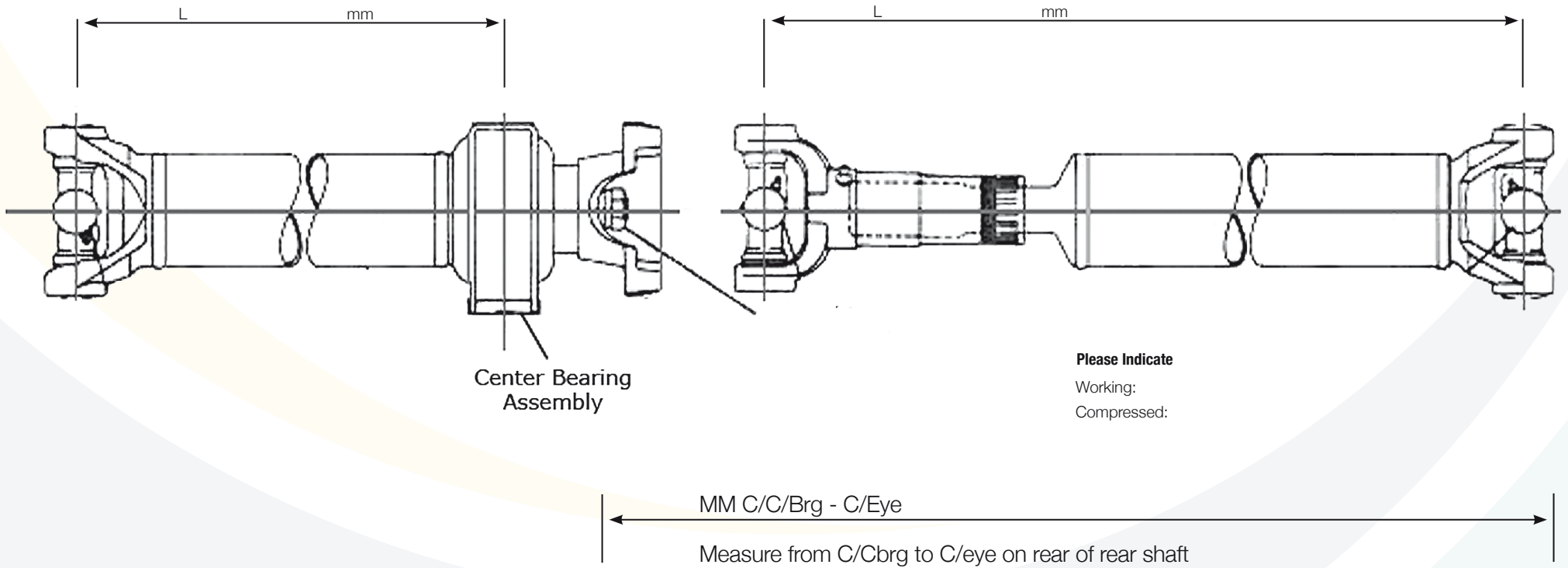

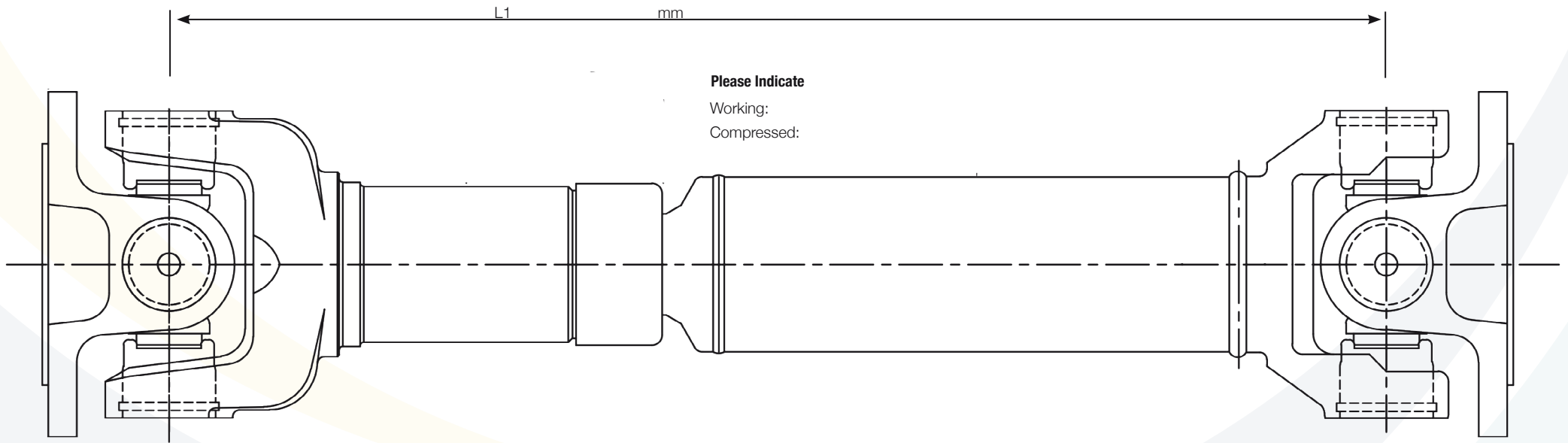

Flange can have 4, 6, 8, 10 or 12 spaced holes

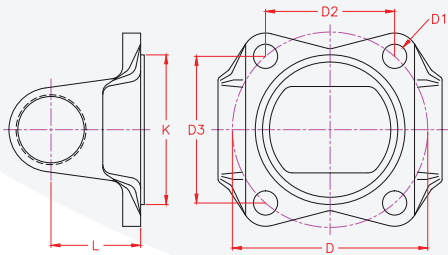

Type 1

Flange can have 4, 6, 8, 10 or 12 spaced holes

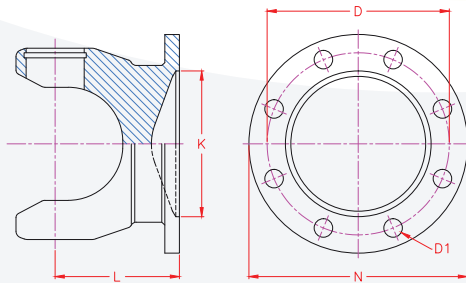

Type 2

Flange can have 8 or 12 holes

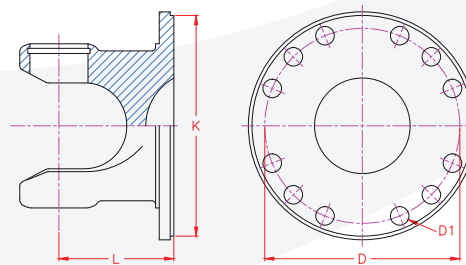

Type 3

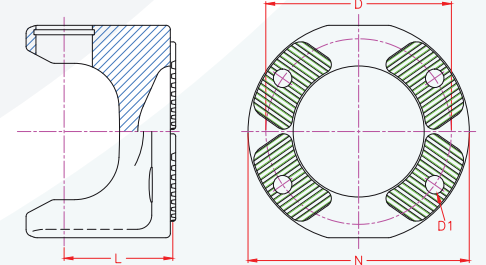

Type 4

Please Indicate

Working:

Compressed:

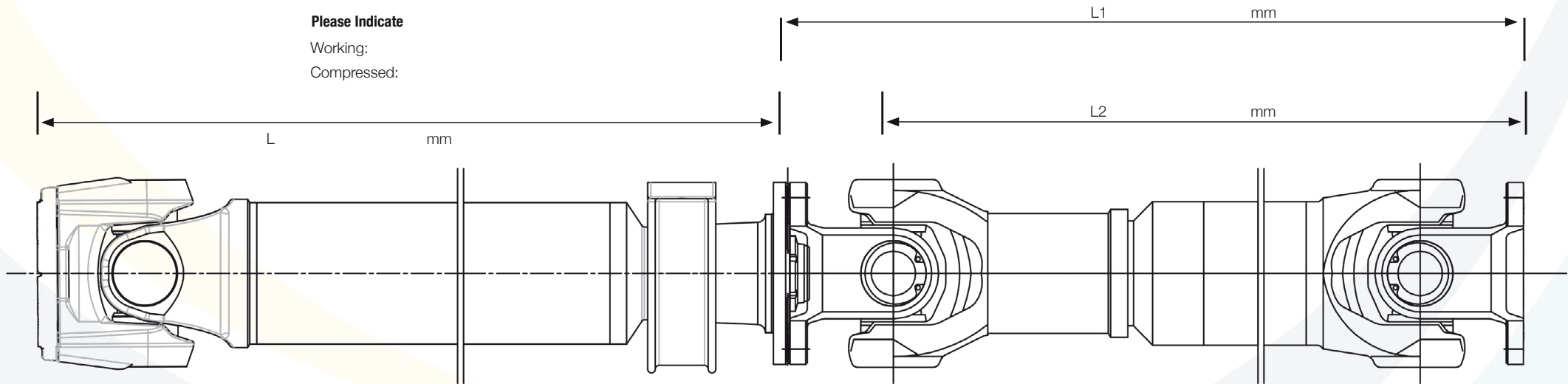

Flange can have 4, 6, 8, 10 or 12 spaced holes

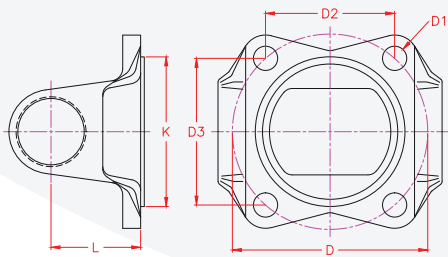

Type 1

Flange can have 4, 6, 8, 10 or 12 spaced holes

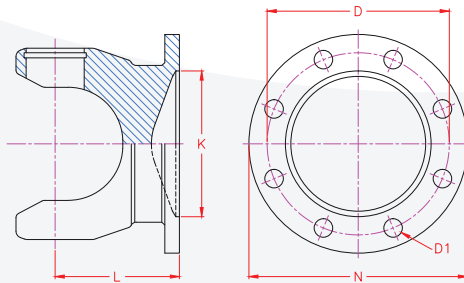

Type 2

Flange can have 8 or 12 holes

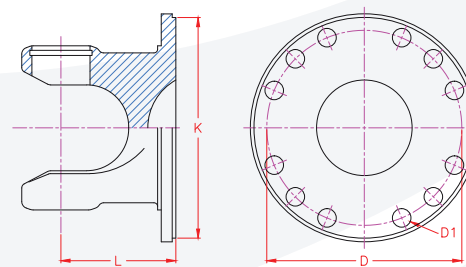

Type 3

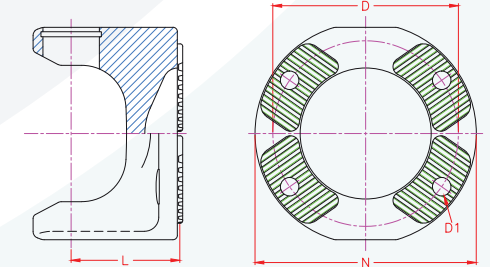

Type 4

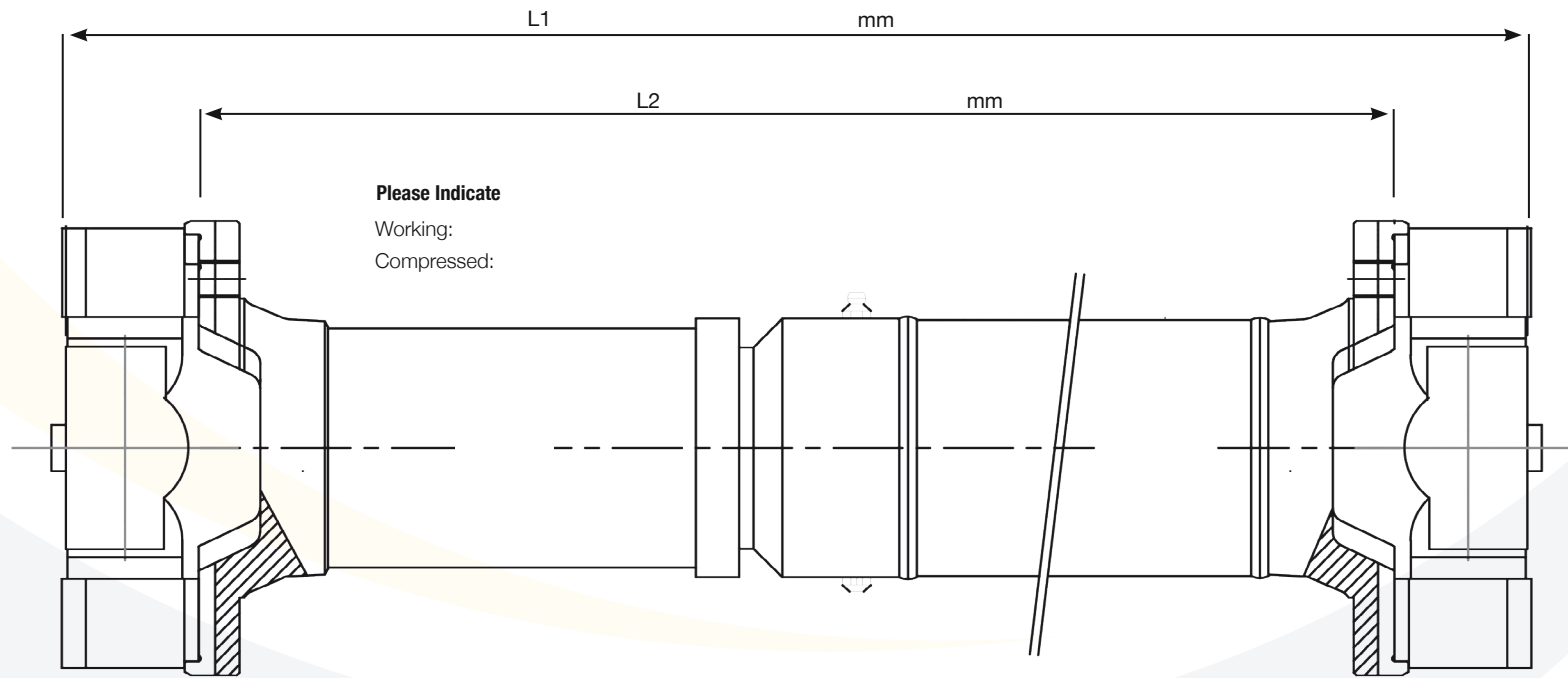

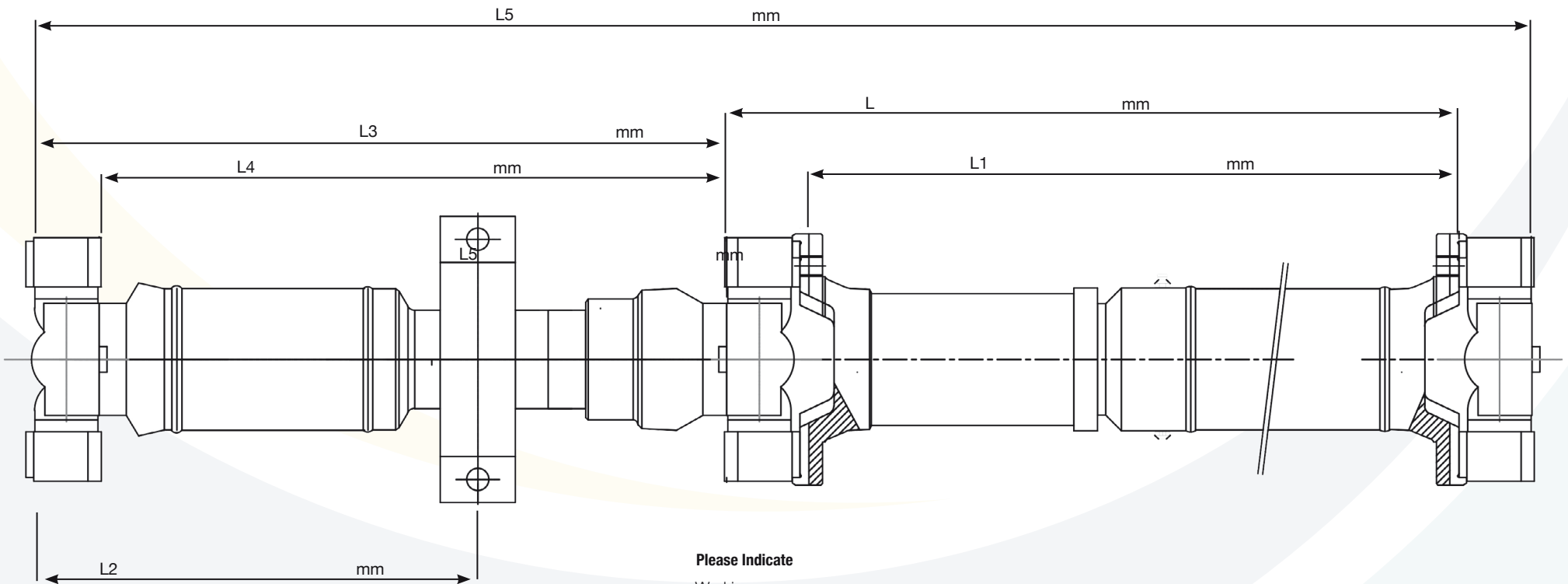

Please Indicate

Working:

Compressed:

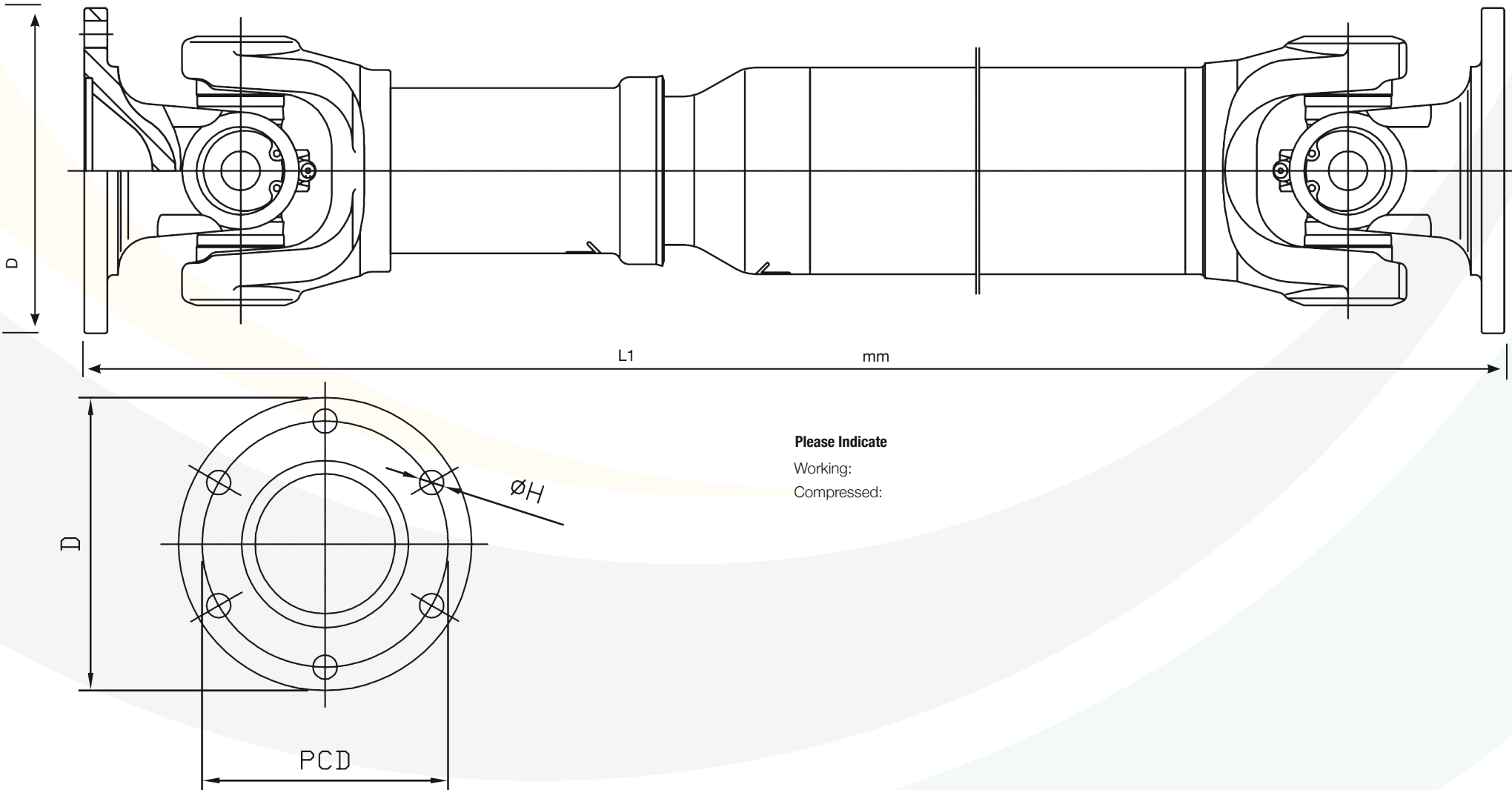

Please Indicate

Working:

Compressed:

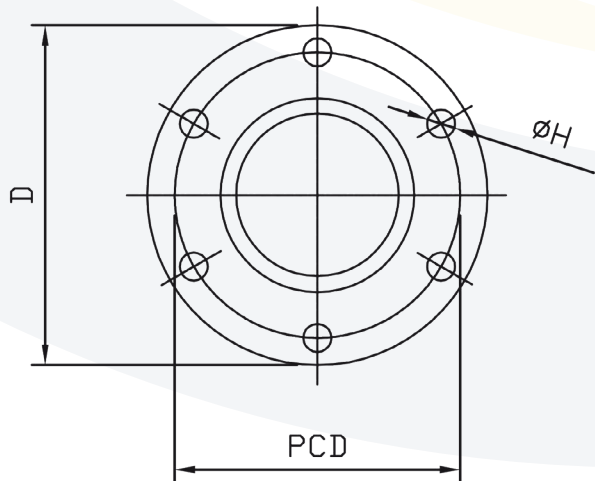
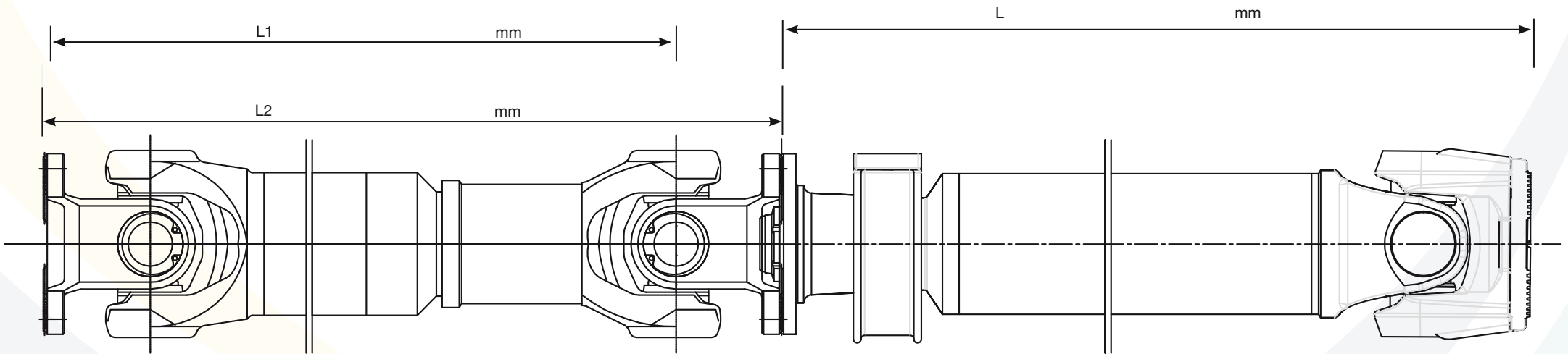

Please Indicate

Working:

Compressed:

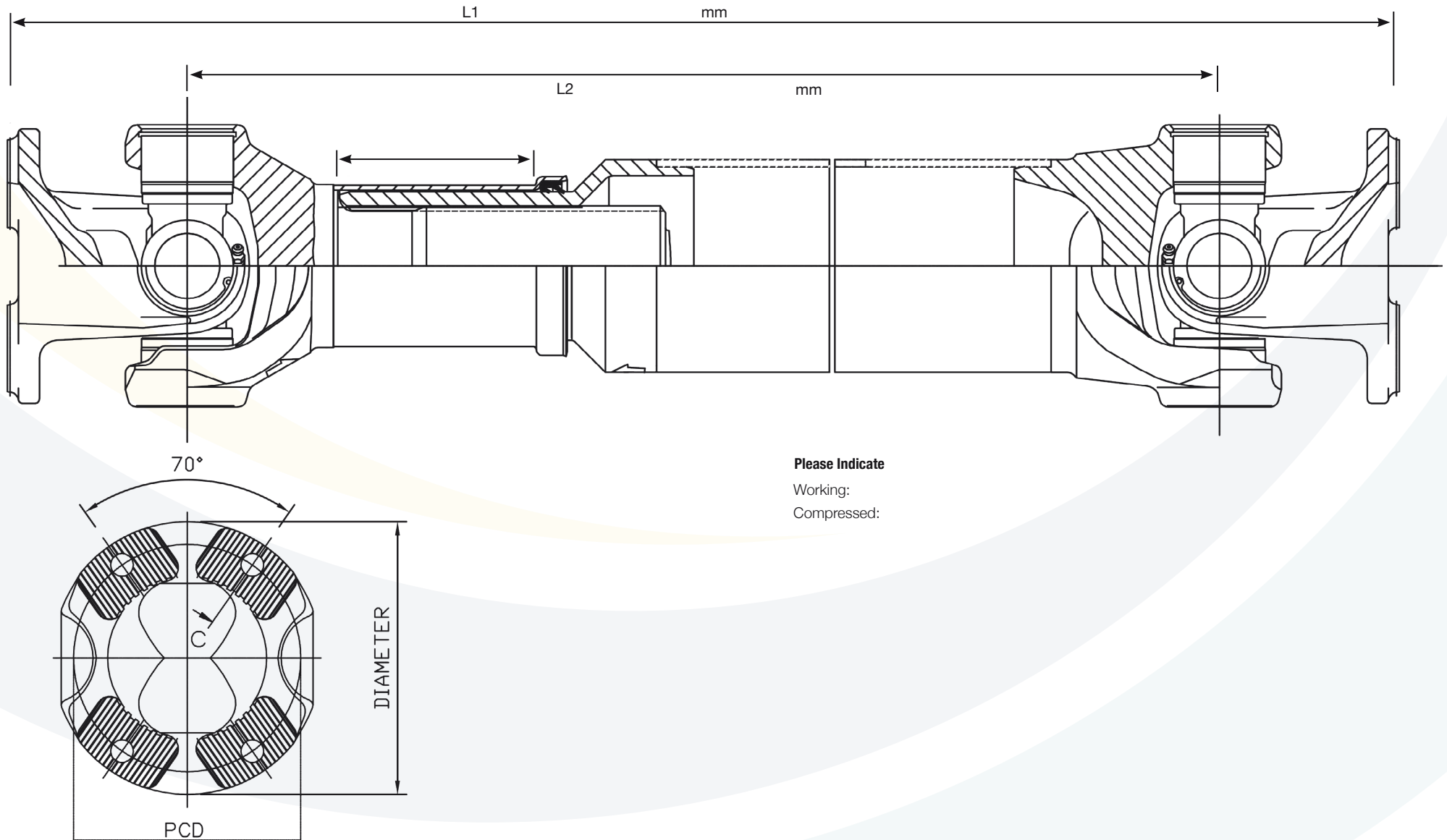

Please Indicate

Working:

Compressed:



“ The Driveline Group is a national network of 100 staff and twelve fully equipped CRM controlled branches ”



CONTACT US

BRISBANE | BROKEN HILL COBAR | DUBBO | MACKAY

MELBOURNE | NEWCASTLE | PERTH | SYDNEY | TOWNSVILLE



1300-DRIVELINE



DRIVELINE.COM.AU